



QS:B220™

DESKTOP EXPLOSIVES & DRUGS TRACE DETECTOR

Simultaneous detection of trace amounts of explosives and drugs in real-time

The QS:B220 combines the latest in ion mobility spectrometry (IMS) analysis technology with unmatched ease-of-use and an industry-leading low maintenance design. Defining the new standard in trace detection, the system performs simultaneous detection of a wide variety of explosives and drugs, and delivers results in seconds. Results are displayed on screen and can be printed on the integrated thermal printer or on an optional external printer.

The QS:B220's large high-resolution touch-screen, with more than 40% viewing area than other explosive trace detection (ETD) systems, makes operating the system simple. All functions are accessed through dynamic touch buttons that present screeners only the options necessary to get the job done. Authorized users can also access spectrogram analysis, administrative, and diagnostics tools.

Built for better resolving power and faster clear-down, the QS:B220 delivers superior detection performance with low false alarm rates. The patented inCal™ automatic internal calibration system uses no consumables and does not require any action by the system operator, so screeners can focus on security.

Operational costs are extremely low with the QS:B220. Common maintenance procedures are fully automated and can be activated by simply pushing a button on the system's touch-screen menu system. Long life dopants and calibrants last for years without replacement. Routine service consists of cleaning using common supplies, and desiccant replacement as required.

No radioactive material is used in the QS:B220. There are no associated certification, licensing, inspection, testing, transportation, or decommissioning costs.

BENEFITS

- Simultaneously detects explosives and drugs in seconds
- inCal automatic calibration
- Intuitive touch-screen controls
- Non-radioactive ion source
- Push-button maintenance
- Low false alarm rate
- Remote diagnostics
- Low total cost of ownership
- Global certifications - EU Standard, TSA Checkpoint and ACSTL

FOR MORE INFORMATION

leidos.com/ETD



Specifications

GENERAL

HEIGHT:

39.9 cm with printer

WIDTH:

42.5 cm with printer

DEPTH:

40.40 cm with printer

WEIGHT:

618.9 mm (24.4") W x 15.7 kg with printer

DETECTOR TYPE

Ion Mobility Spectrometry

POWER REQUIREMENTS

INPUT VOLTAGE:

100-240 VAC, 47-63 Hz

POWER CONSUMPTION:

350 watts peak (225 watts typical)

DATA DISPLAY

31.8 cm high-resolution color touch-screen

SAMPLING RATE

Minimum of 180 samples per hour when no alarm occurs

Automatic clear-down requires no user intervention

Typical clear-down time is less than 10 seconds

WARM UP TIME

30 minutes maximum

SAMPLE ACQUISITION

Particulate collection via wiping (wand or with golved hand)

CALIBRATION

inCal automatic internal calibration system

ALARM METHOD

Configurable visual and audible alarms

Substance identification by name (depending on configuration)

CONSUMABLE MATERIALS

Low-cost molecular sieve drying agent (desiccant)

High-durability sample traps (ECAC certified - reusable up to 25 times)

Additional preventative maintenance supplies as required

EXPANDABILITY AND CONNECTIVITY

4 USB 2.0 ports for accessories such as an optional keyboard, printer and mouse. RJ-45 ethernet network port supports control station monitoring, remote control, and remote diagnostics. VGA port.

OPERATING ENVIRONMENTAL

OPERATING TEMPERATURE:

-10°C to 55°C (14°F to 131°F)

ALTITUDE:

Up to 4,572 m (15,000ft)

RELATIVE HUMIDITY:

0 to 95%, non-condensing

SUBSTANCES DETECTED

Explosives: Military, commercial, and homemade explosives (HMEs) including: ammonium, nitrate, ANFO, black powder, C-4, detasheet, detonating cord, dinitrotoluene, DMNB, dynamite, EGDN, HMTD, HMX, nitroglycerin (NG), o-MNT, peroxides, PETN, RDX, semtex, smokeless powder, tetryl, triacetone triperoxide (TATP), trinitrotoluene (TNT), urea nitrate, and others.

Drugs: Cocaine, heroin, ketamine, L-amphetamine, LSD, MDA, MDMA, methamphetamine, morphine, PCP, spics, THC, and others.

Additional substances can be added through the user-expandable detection library.

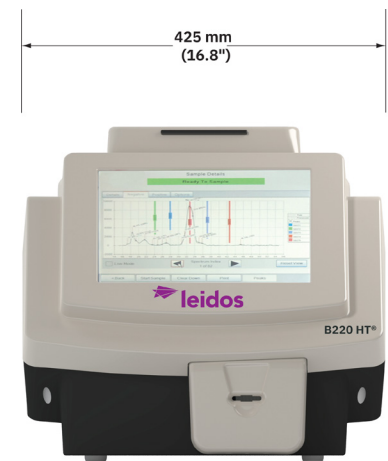

Front View

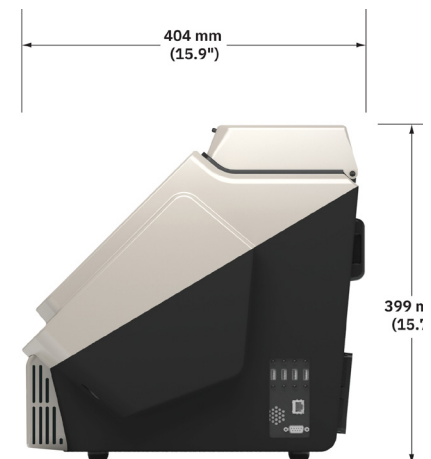

Side View

FOR MORE INFORMATION

leidos.com/ETD